

M-Bus Option Card

Installation Instructions

GENERAL

This document covers mounting and wiring of the M-Bus Option Card into the Tridium Jace 2xx, Jace 6xx and Jace M2M. It can connect up to 10 M-Bus metering devices, while protecting the Jace from short-circuits on the bus. No additional parts are needed - the card uses the built-in serial port and power supply on the Jace. Only one card can be installed in the Jace!

SAFETY INSTRUCTIONS

These instructions include indications for use and mounting of the device. In case of questions that cannot be answered with these instructions, please consult Neopsis GmbH. It is the responsibility of the equipment installer to ensure that all federal, state and local codes are followed.

- Only qualified personnel shall do mounting and installation work with these devices. Qualified personnel in the sense of these instructions are persons who are well versed in the use and installation of such devices and whose professional qualification meets the requirements of their work.
- The information in these instructions must be read and understood by every person using this device.

BEFORE INSTALLATION

Unpack the Option Card and check the equipment. Included in this package is the M-Bus Option Card and the Installation Instructions. Report any damage to Neopsis support. Read all instructions and ensure you understand what you are doing. The following tools and supplies are required for installation:

- #2 Phillips screwdriver used to install the M-Bus Option Card.

MOUNTING

Power to the Jace Controller must be OFF when installing or removing M-Bus Option Card or damage will occur! Also, be very careful to align the pins properly

You can mount the M-Bus Option Card in either of the available slots, but only one card can be installed per Jace.

1. Power down the Jace
2. Remove the Jace cover

3. Remove the battery and brackets assembly by taking out the four screws holding it in place. Unplug the battery from the connector on the Jace base board.

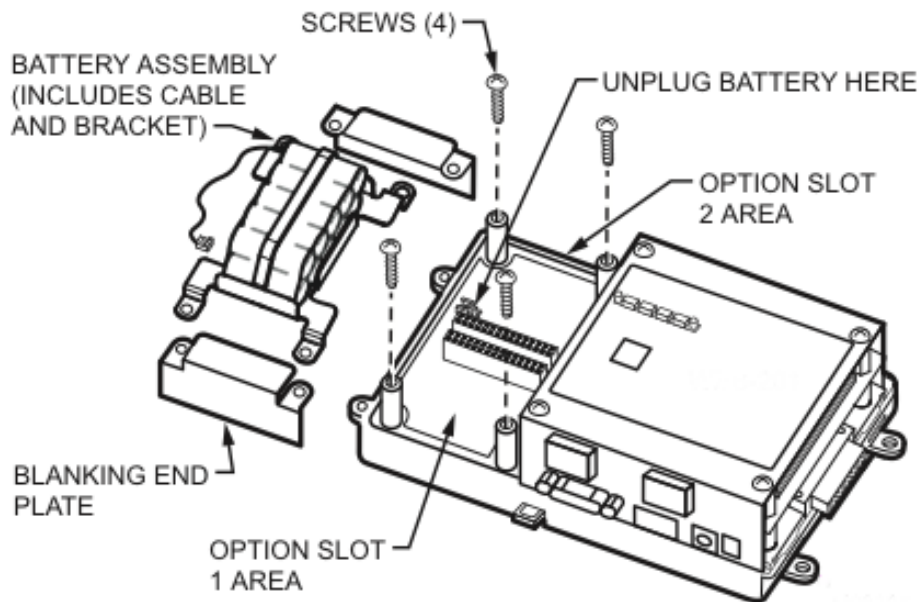

4. Remove the blanking end plate for the slot in which you plan to install the card.
5. Carefully insert the pins of the M-Bus Option Card into the socket of the appropriate slot. Check the pin alignment! Press until the M-Bus Option Card is completely seated.
6. Plug the battery cable into the connector on the Jace base board.
7. Set the battery and bracket assembly back over the option card slots, with the mounting holes aligned with the standoffs.
8. Place the four screws through the battery bracket and the end plate into the standoffs on the Jace base board. Hand tighten these screws.
9. Replace the Jace cover.

WIRING

Connect the M-Bus communication wiring to the 2-position connector of the Option Card. The M-Bus wiring is polarity independent. Refer to the M-Bus specification for technical guidelines associated with the bus topology.

LEDs

Three LEDs are visible on the M-Bus Option Card end plate. From left to right:

- | | |
|--------------|--|
| Yellow - TxD | Sending data to the MBus |
| Red - Error | Short circuit indicator, 60 mA current limitation active |
| Yellow - RxD | Receiving data from the MBus |